

# 6226 - 0003 Footswitch

Special double-pedal version of 6226 series footswitch with IPX7 rating

- Low profile, rear hinged switch designed for improved user comfort
- Grey cover with Herga logo fitted on a black base
- Fitted to a black moulded 2 pedal base
- Momentary action with normally open contacts
- Option for customers to fit own cable
- According to IEC60601 IEC/UL



## Reference dimensions

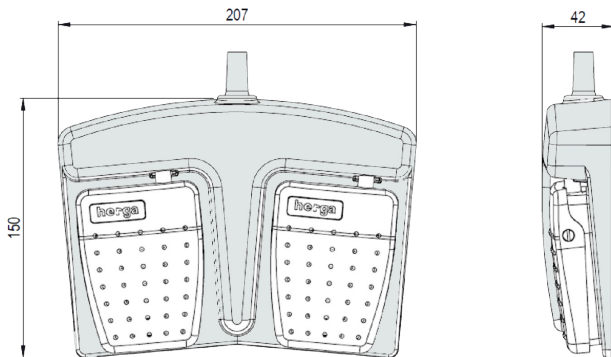

The 6226-0003 is a stock model

## General specifications

**Standards/approvals** the individual Footswitch : UL file reference E353500  
ANSI/AAI ES60601-1, A1:2012, C1:2009/(R) 2012 and A2:2010 (R) 2012  
CSA CAN/CSA-C22.2 No 60601-1-14  
IEC 60601-1 Ed 3.1 (2012)  
EN 60601-1:2006 & A1:2013 & A12:2014  
BS EN 62368-1:2014 & A11:2017

**Degree of protection** EN 60529 IPX7

**Connection method** 2 metres of 3-core cable

**Max. electrical rating** 3A 24VAC/DC

**Contact configuration** Normally Open contacts

**Action** Momentary

**Operating temperature range** -20°C to +60°C

**Body material** Thermoplastic

**Weight** 550 grams (including cable)

**Additional information** Customized versions available (logos, cordsets, colours, guards)

## Accessories

Part Number	Description
6202-0001	Single Black RAL 9005 guard
6202-0002	Single Grey RAL 7035 guard
6202-0003	Twin Grey RAL 7035 guard

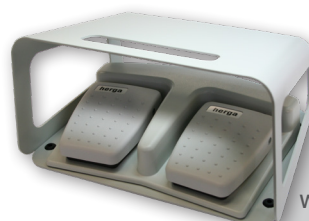

With 6202 Guard